



Mobile Filtration Unit MFU-10 MFU-15

Description

The Mobile Filtration Unit MFU is used as a portable service unit for filling hydraulic systems, flushing small hydraulic systems and for cleaning in bypass flow. Solid particle contamination as well as free water can be removed by the filter elements.

The MFU can also be fitted with a CS 1000 Contamination Sensor. This allows the solid particle contamination in the oil to be monitored at the same time. The cleanliness class results are displayed according to ISO, SAE or NAS classifications.

Fields of application

- Filtered and unfiltered filling of hydraulic systems
- Temporary offline filtration of hydraulic systems
- Filtered and unfiltered fluid transfer
- Unfiltered drainage of hydraulic tanks
- Leakage oil recirculation at test benches

Special features

- Improvement in life expectancy for components and system filters
- Increased oil life expectancy
- Increased machine availability
- Simple operation
- Compact design
- Integrated dry-running protection
- Option: CS 1000 ensures continuous monitoring of oil cleanliness during cleaning

Technical data

General data	MFU-E	MFU-S	MFU-P
Flow rate, maximum	15 l/min	15 l/min	10 l/min
Pump type	Vane pump		
Operating pressure, maximum	4.0 bar		
Permitted suction pressure at suction port	-0.4 bar to 0.5 bar		
Viscosity range	5 to 350 mm ² /s	5 to 650 mm ² /s	5 to 200 mm ² /s
Length of connection cable	3 m (including male connector)		
Length of signal cable (for standard type)	-	10 m	-
Permitted fluid temperature range	-10 to 80 °C		
Permitted ambient temperature range	-10 to 40 °C		
Seal material	FKM (FPM, Viton®)		
Weight when empty	≈ 14 kg	≈ 17 kg	≈ 16.5 kg

Preferred models (with shorter delivery times)

Filter unit	Part no.:
MFU-15E9-SM-FE	4263416
MFU-15S9-SN-FE	4269896
MFU-10P9-SM-FE	4263417

Model code

MFU - 15 E 9 - S M - F E /-

Basic type

MFU = MobileFiltration Unit

Model

10 = 10 l/min (for type P)

15 = 15 l/min (for type E and S)

Type code

E = Economy

S = Standard (with signal cable for "device in operation")

P = Premium (with Condition Monitoring)

Filter element length

9 = 9"

Pump version

S = vane pump

Supply voltage

D = compressed air (not available for type S or P)

K = 120 V, 60 Hz, 1 Ph (0.25 kW for type E and P; 0.37 kW for type S)

M = 230 V, 50 Hz, 1 Ph (0.25 kW for type E and P; 0.37 kW for type S)

N = 400 V, 50 Hz, 3 Ph (0.37 kW) (not available for type E or P)

T = 12 V DC (0.2 kW) (not available for type S)

U = 24 V DC (0.2 kW) (not available for type S)

Others on request

Sealing material

F = FKM (FPM, Viton®)

Others on request

Clogging indicator

E = back-pressure indicator

Supplementary details

Scope of delivery

- MFU (without filter element, without hoses)
- Operation and maintenance instructions

Filter elements and hoses must be ordered separately and installed before operation on site. For this purpose, please observe the next page.

Filter elements

	Designation	Part no.	Filter unit	Water absorption
Filtration	NX9DM002-F	4265955	2 µm	-
	NX9DM005-F	4265956	5 µm	-
	NX9DM010-F	4265957	10 µm	-
	NX9DM020-F	4265958	20 µm	-
Filtration + dewatering	NX9AM002-F	4265959	2 µm	√
	NX9AM005-F	4265960	5 µm	√
	NX9AM010-F	4265961	10 µm	√
	NX9AM020-F	4265962	20 µm	√
Adapter for unfiltered operation	NX9-xxxxx-F	4265963	-	-

Accessories

Hoses with lance (depressurised suction up to max. 350 mm²/s)

Designation	Part no.	Suction hose/ pressure hose	Lance	Material of suction/pressure hose
E-MFU-15-SDN	4270478	2.5 m / 2.5 m	0.25 m	PVC / PVC
E-MFU-15-SDF	4270479	2.5 m / 2.5 m	0.25 m	1SN / 2TE
E-MFU-15-SD5N	4270480	2.5 m / 5.0 m	0.25 m	PVC / PVC
E-MFU-15-SD5F	4270481	2.5 m / 5.0 m	0.25 m	1SN / 2TE

Hoses with threaded connection (depressurised suction up to max. 350 mm²/s)

Designation	Part no.	Suction hose/ pressure hose	Thread	Material of suction/pressure hose
E-MFU-15-SKDKN	4270482	2.5 m / 2.5 m	M30X2 / M26X1,5	PVC / PVC
E-MFU-15-SKDKF	4270483	2.5 m / 2.5 m	M30X2 / M26X1,5	1SN / 2TE
E-MFU-15-SKDK5N	4270484	2.5 m / 5.0 m	M30X2 / M26X1,5	PVC / PVC
E-MFU-15-SKDK5F	4270516	2.5 m / 5.0 m	M30X2 / M26X1,5	1SN / 2TE

Accessories for hoses with threaded connection

Designation	Part no.	Function
E-MFU-15-SKDK-LF	4270559	Lance ¹ (1.30 m length)
E-MFU-15-SKDK-SF	4270560	Suction filter ¹
E-MFU-15-SKDK-ZWF	4270518	Counter
E-MFU-15-SKDKN-ZPF	4270561	Filling nozzle ²
E-MFU-15-SKDKN-ZPWF	4270519	Filling nozzle & counter ²

¹ Max. viscosity 200 mm²/s

² Max. duration of unit operation with filling nozzle closed 5–10 min. Only use filling nozzle with 1 SN / 2 TE hoses

Dimensions

MFU-10P

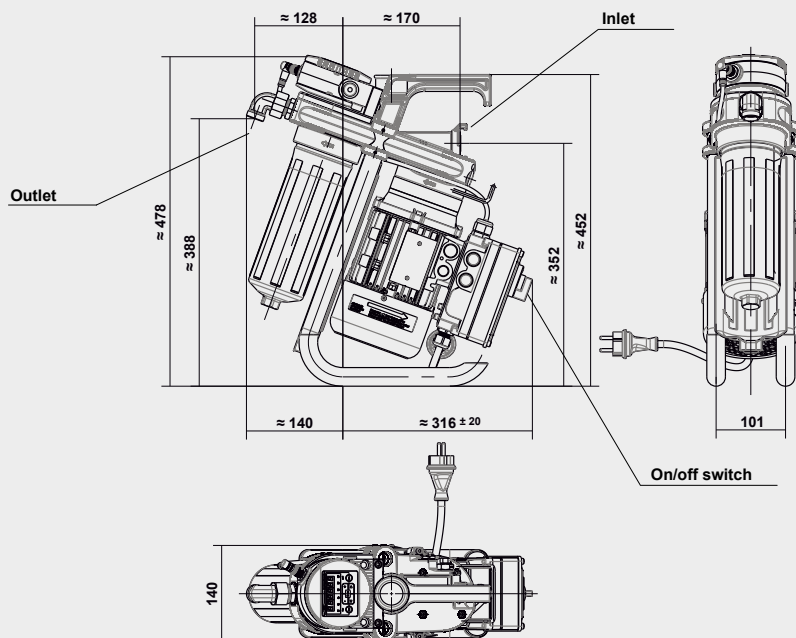

All dimensions in mm

Hydraulic circuit diagram

MFU-10P

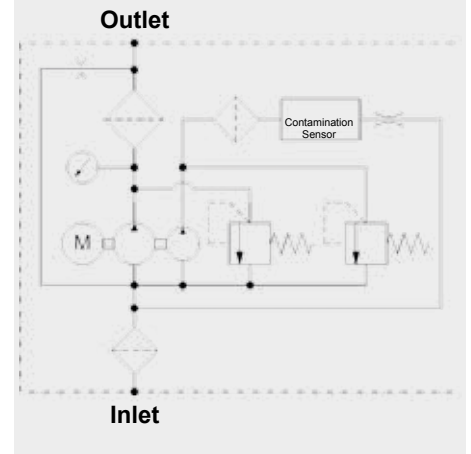

Dimensions

MFU-15E

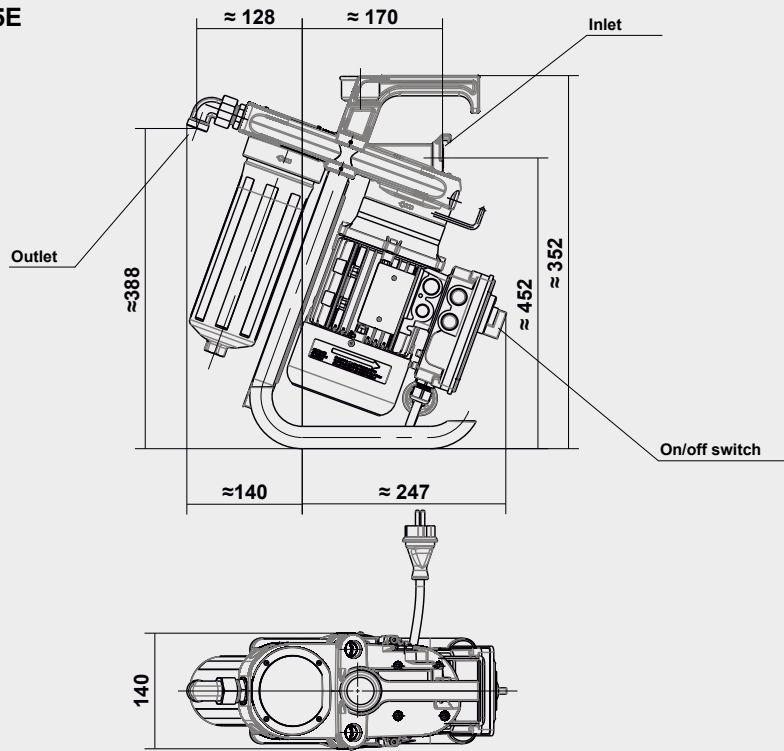

All dimensions in mm

Hydraulic circuit

MFU-15E

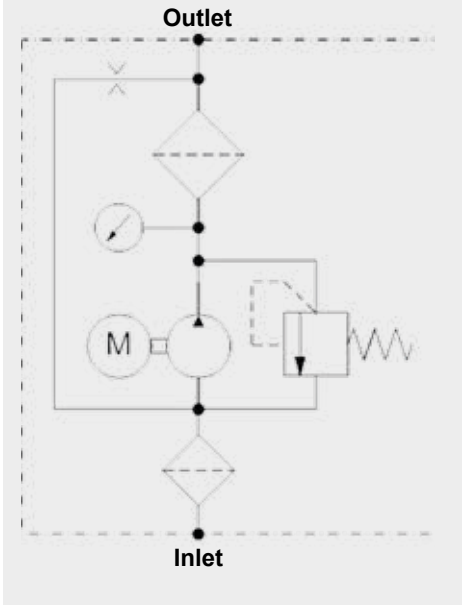

Dimensions

MFU-15S

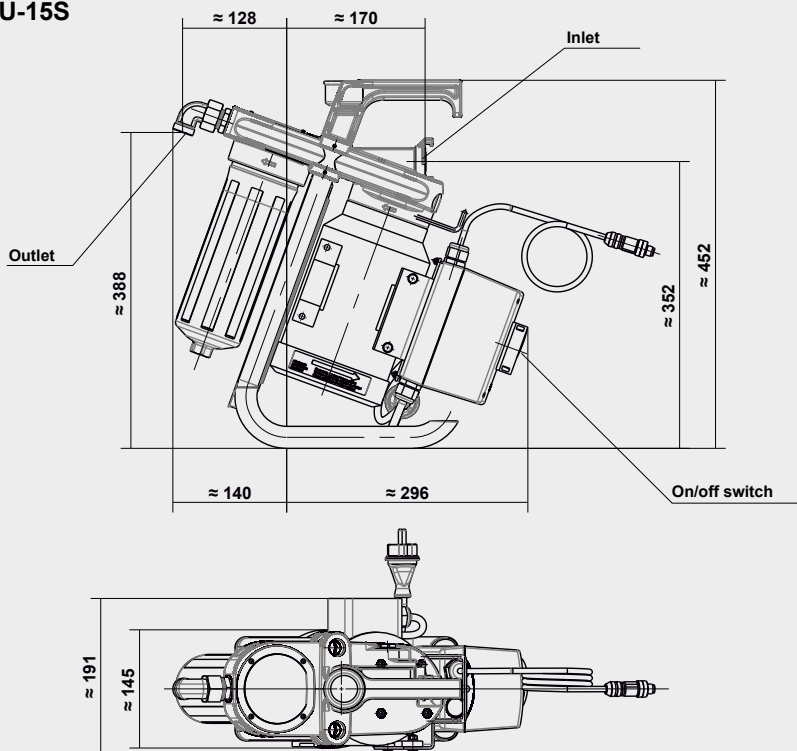

All dimensions in mm

Hydraulic circuit

MFU-15S

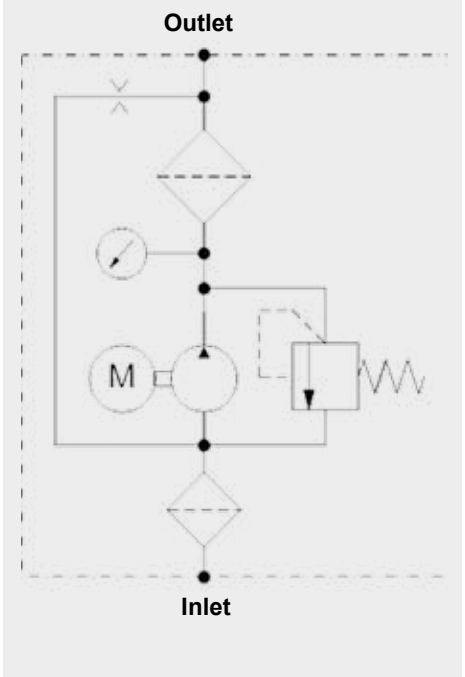

Notice

The information in this brochure relates to the operating conditions and applications described.

For applications or operating conditions not described, please contact the relevant technical department.

Subject to technical modifications.

HYDAC FILTER SYSTEMS GMBH

Industriegebiet

D-66280 Sulzbach / Saar

Tel.: +49 (0) 6897/509-01

Fax: +49 (0) 6897/509-9046

Internet: www.hydac.com

E-mail: filtersystems@hydac.com